

EPSON[®]
EXCEED YOUR VISION



Epson PowerLite[®] Pro Z8000WUNL MULTIMEDIA PROJECTOR



▲ Image pictured with lens

Powerful performance beyond Hi-Def.

A powerful performer that's easy to install, manage and maintain, the Epson PowerLite Pro Z8000WUNL multimedia projector offers 6000 lumens of color light output and 6000 lumens of white light output for captivating presentations in virtually any venue. With WUXGA widescreen resolution, innovative LCD chips and a contrast ratio up to 5000:1, the Z8000WUNL delivers brilliant widescreen images in lecture halls, conference centers and more. Offering a full suite of monitor and control features, this high definition, high brightness projector ensures easy integration with complex devices, plus a lower overall cost of ownership. Choose from a variety of optional lenses.

A powerful combination of brightness, resolution and true-to-life color —

6000 lumens color light output, 6000 lumens white light output,* WUXGA widescreen resolution and 3LCD, 3-chip technology

Innovative technology for added reliability — durable LCD chips and a new cooling system and filter design



Epson PowerLite® Pro Z8000WUNL

MULTIMEDIA PROJECTOR

The best-selling projectors in the world.

Epson offers a wide range of high-quality projectors to meet almost any need. Built with image quality and reliability in mind, Epson projectors enhance communication and inspire collaboration, while offering a low total cost of ownership. From projectors designed for educational settings to auditorium or boardroom-ready business projectors, Epson has the model made to meet the most demanding needs.



3LCD technology — for quality and color that's beyond amazing

Innovative technology with proven reliability

- 3 chips for vibrant, true-to-life color
- 25% less electricity required per lumen when compared to 1-chip DLP projectors**
- Road-tested reliability from a company with over 20 years of experience

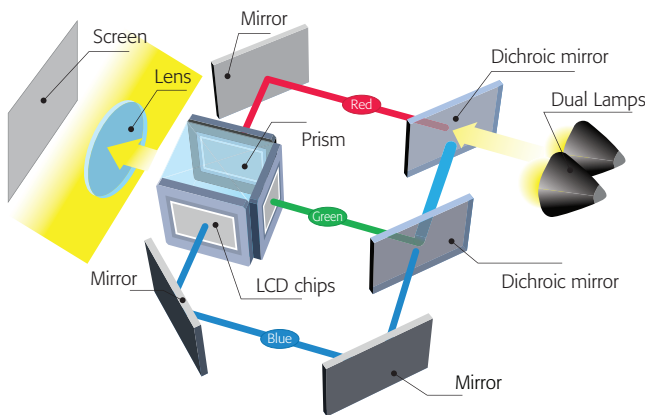

▲ 3LCD technology

Quiet, reliable liquid cooling system

Epson's innovative system uses liquid to cool the LCD chips directly. The liquid absorbs the heat and is then cooled by a peltier device, which is then cooled by a fan, thereby keeping the overall optical engine cool. This system design promotes greater reliability and enables stable operation in temperatures up to 113 °F (45 °C). In addition, it offers quiet, unobtrusive operation and allows for off-axis installation orientations.

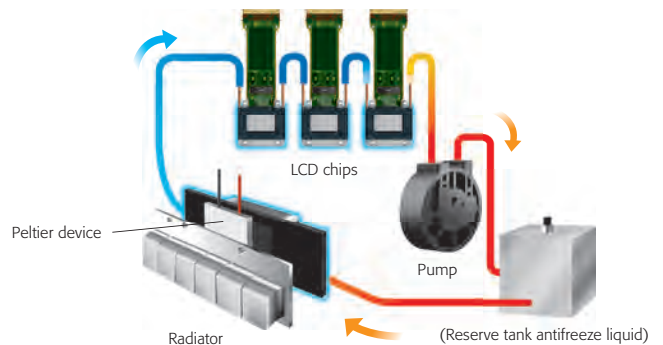

C²Fine® technology delivers blacker blacks

C²Fine offers smooth, uniform images with exceptional contrast for better image quality.



Based on this new phase-compensation technology, light leakage is eliminated, allowing for the reproduction of blacker blacks. C²Fine technology is combined with an auto iris, which allows for a contrast ratio up to 5000:1.



Eco features

- Energy-efficient 3LCD technology
- Designed to be recycled***

Better Products for a Better Future™

For more information on Epson's environmental programs, go to eco.epson.com

Precision control

Convenient lens design

With its centered lens design, the PowerLite Pro Z8000WUNL makes installation easy to plan. Positioning the ceiling mount, screen, and projector can be performed individually and independent of one another.



Six powered lens options

With a 1.6x standard lens, the PowerLite Pro Z8000WUNL offers increased placement flexibility. For even greater flexibility, Epson offers a total of six lenses with varying ranges including short, wide, and rear, along with mid-to long-throw lenses that allow users to choose the motorized lens most suited for their environment. A quick release lever allows for a quick, easy lens exchange. (Lens not included)



▲ Lens not included

Off-axis, flexible installation

The PowerLite Pro Z8000WUNL can be rotated 90 degrees upward or downward with an additional 30-degree tilt operation for off-axis positioning flexibility. As a result, it can be used for a wide range of applications, such as projecting on the ceiling or floor, or as part of a rear-projection system. Epson technology keeps the projector running without compromising performance or causing overheating.



▲ Ceiling projection



▲ Floor projection

Epson lens shift technology

In addition to added reliability and amazing color performance, 3LCD's industry-leading technology enables the projector to achieve a wide range of lens shift capabilities. This lens shift technology enables outstanding installation flexibility with an incredible range of + or - 70% on the vertical axis and + or - 20% on the horizontal axis. Users can operate the vertical lens shift function using the remote control, the projector control panel, or control commands.



Description/Product #	Throw ratio/Screen size	Focal length/F #
ELPLS04 Standard Zoom Lens V12H004S04	Throw Ratio: 1.74 – 2.82:1 Screen Sizes: 60" – 500" Zoom Ratio: 1 – 1.61:1	Focal Length: 36.00 mm – 57.35 mm F/#: 1.65 – 2.51
ELPLR04 Rear-projection Wide Lens V12H004R04	Throw Ratio: 0.77:1 Screen Sizes: 60" – 500"	Focal Length: 16.15 mm F/#: 1.85
ELPLW04 Wide Zoom Lens V12H004W04	Throw Ratio: 1.31 – 1.80:1 Screen Sizes: 60" – 500" Zoom Ratio: 1 – 1.37:1	Focal Length: 27.32 mm – 37.04 mm F/#: 1.8 – 2.26
ELPLM06 Middle-throw Zoom Lens #1 V12H004M06	Throw Ratio: 2.68 – 4.1:1 Screen Sizes: 60" – 500" Zoom Ratio: 1 – 1.5:1	Focal Length: 55.43 mm – 83.3 mm F/#: 1.81 – 2.4
ELPLM07 Middle-throw Zoom Lens #2 V12H004M07	Throw Ratio: 3.92 – 5.97:1 Screen Sizes: 60" – 500" Zoom Ratio: 1 – 1.5:1	Focal Length: 80.59 mm – 121.1 mm F/#: 1.81 – 2.34
ELPLL07 V12H004L07 Long-throw Zoom Lens	Throw Ratio: 5.83 – 8.18:1 Screen Sizes: 60" – 500" Zoom Ratio: 1 – 1.39:1	Focal Length: 118.98 mm – 165.39 mm F/#: 1.8 – 2.45

▲ Lens throw chart

Quality and reliability

Beyond Hi-Def

With WUXGA resolution (1920 x 1200), the PowerLite Pro Z8000WUNL delivers high quality images and crisp, sharp text without any distortion or scaling. And, it makes it easy to display more content. In fact, with the Z8000WUNL, the display area can accommodate two independent, A4-sized windows, side by side, at the same time. You can also display HDTV content at its native resolution with quality that surpasses even that of 1080p devices. WUXGA resolution is ideal for any application requiring full Hi-Def, including Blu-Ray® content, graphic intensive programs, educational film slides, and any application requiring exceptional detail.

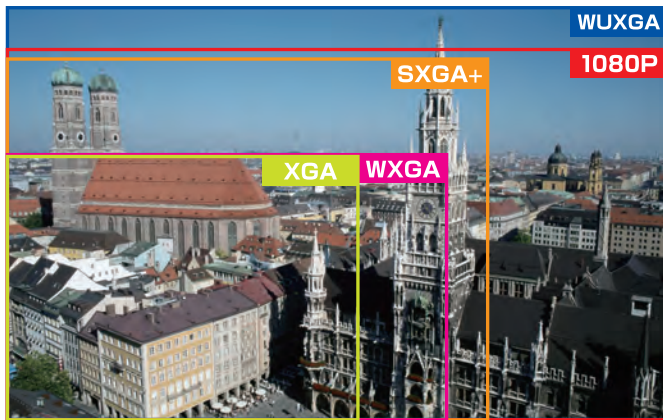

▲ WUXGA resolution

Powerful, large venue performance

The PowerLite Pro Z8000WUNL combines the brightness of 6000 lumens color light output and 6000 lumens white light output* with the detail of widescreen WUXGA resolution, backed by the power of 3LCD technology. Surpassing 1080p Hi-Def performance, this projector delivers captivating presentations and videos in virtually any venue. This amazing, flexible performer was engineered and designed for easy integration, with installation features that even the most savvy professional installer would appreciate. With WUXGA (1920 x 1200) resolution, durable 3LCD chips and a contrast ratio up to 5000:1, the Z8000WUNL meets complex venue requirements. It delivers brilliant widescreen images for presentations in lecture halls, auditoriums, conference centers and houses of worship. It also offers a full suite of monitor and control features that contribute to a low cost of ownership.



Low cost of ownership

Protect your investment — long-life electrostatic air filter

The PowerLite Pro Z8000WUNL filter is designed to protect the optical engine, lamp and electronics from small dust particles that can enter any projector. It has a recommended 10,000-hour filter cleaning schedule. The Epson electrostatic filter captures particles as small as 3 microns, due in part to its pleated, expanded design. With one air intake and one exhaust path, the PowerLite Pro Z8000WUNL offers an efficient airflow system for optimum cooling of key components and a reduction in dust-related problems. Additionally, it has the capability to send an e-mail notification out through the Epson Monitor utility when an increase in temperature is detected, due to clogging.



▲ Easy access filter

Easy maintenance and monitoring

With convenient access to the lamps and filter, the PowerLite Pro Z8000WUNL makes maintenance easier than ever, even if the projector is ceiling mounted. The lamp cover is located on the rear side panel and there are no screws, so the lid can be removed without any special tools. In addition to easy lamp and filter replacements, the Z8000WUNL includes features that make it easy to monitor and control. With EMP Monitor, users can access advanced status functions over the LAN network.



Powerful performance

Quality and reliability

- **Powerful combination of brightness, resolution and true-to-life color** — 6000 lumens color light output, 6000 lumens white light output,* WUXGA resolution and 3LCD, 3-chip technology
- **Core technology for added reliability** — durable LCD chips; innovative cooling system and filter design
- **Digital connectivity for 1080p, full Hi-Def performance** — HDMI with HDCP compliancy and DVI-D, both with high-grade video processing
- **Exceptional color fidelity** — broad color reproduction covers the DCI color gamut space for viewing movies as film producers intended
- **Greater detail with blacker blacks** — C²Fine[®] technology, up to 5000:1 contrast ratio cinema filter

Precision control

- **Easier installation** — center lens design makes it easy to align the projector with the screen
- **Powered lens** — motorized zoom, focus, and lens shift, controllable through the remote, RS-232 or IP
- **Wide lens shift capabilities** — vertical positioning of + or - 70%, + or - 20% horizontal
- **Perfect for auditoriums and lecture hall venues** — six optional lenses including wide-, rear- and long-throw lenses designed with a change-out lever for easy lens installation
- **Direct On and Direct Off** — allows a projector to be powered on/off by use of a wall switch

Low cost of ownership

- **Protect your investment** — recommended 10,000-hour filter cleaning schedule and easy, side-access filter
- **Easy monitor and control capabilities** — included Epson monitor software allows for remote monitor and control of Epson networked projectors
- **Value-added features** — Quick Corner[®] for independent image corner control; built-in closed captioning decoder; cable interface cover
- **Dual lamps with long lamp life** — up to 3500-hour lamp life in ECO Mode, up to 2500 hours in Normal Mode****

Easy Management[®] with Epson Monitor

EasyMP[®] technology makes it easy to monitor and control all networked Epson projectors. You can use the utility while performing help desk services and proactively manage your projector assets. Remotely power down your projector(s) to extend the lamp life and produce energy savings. The utility also allows you to set up e-mail notifications, verify and change internal settings, and more. The utility is packaged on a CD with the projector and can be used with a PC to check the status of a projector. It is also available online at epson.com.

Uninterrupted operation

With two lamps (330 W), the PowerLite Pro Z8000WUNL boasts a dual lamp system that eliminates the risk of interruption. If one lamp were to fail, operation would continue, using the other lamp. And, replacements are made easy with free and unobstructed access to the rear control panel.



▲ Control panel

Advanced installation features

- **Innovative cooling and filter system for venues with more demanding requirements** — perfect for restaurants, gaming venues and sports venues that require dust protection and have a higher performance/usage requirement
- **Off-axis installation for flexible placement** — install the projector so that it's facing up or down, for off-axis signage positioning

